

Side View 1

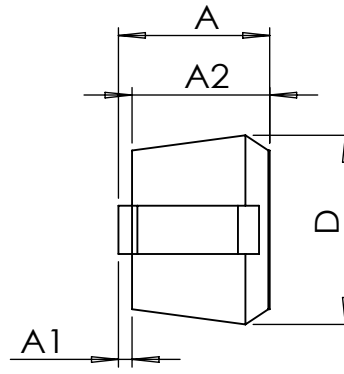

Side View 2

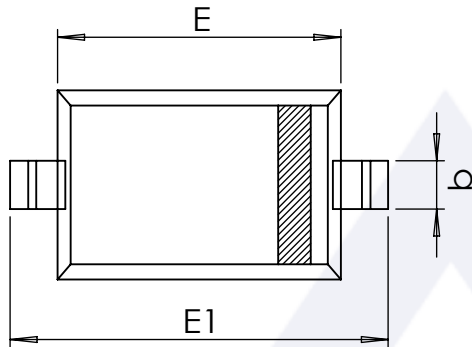

Top View

Symbol	Dimensions in mm			Dimensions in Inches		
	Min.	Typ.	Max.	Min.	Typ.	Max.
A	1.050	1.150	1.250	0.041	0.045	0.049
A1	0.000	0.050	0.100	0.000	0.002	0.004
A2	1.050	1.100	1.150	0.041	0.043	0.045
b	0.450	0.550	0.650	0.018	0.022	0.026
c	0.080	0.130	0.180	0.003	0.005	0.007
D	1.500	1.600	1.700	0.059	0.063	0.067
E	2.600	2.700	2.800	0.102	0.106	0.110
E1	3.550	3.700	3.850	0.140	0.146	0.152
L	-	0.500 REF.	-	-	0.020 REF.	-
L1	0.250	0.350	0.450	0.010	0.014	0.018
θ	0°	-	8°	0°	-	8°

Package Name	Revision	First Angle Projection	Reference			
			IEC	JEDEC	JEITA	-
SOD123-2L (Type A)	Ver. M01 2024.04.24					